

**AL-3000**



**Specifications**

	Number of cavity		3
	Theoretical capacity	BPH	2400*
Container	Max. container volume	liter	2
	Max. outside neck	mm	38
	Max. container diameter	mm	105
	Max. container height	mm	330
Power	Rated power	KW	63
	Max. heating power	KW	60
Compressed air	Operating pressure	MPa	0.7
	Operating air consumption	L/min	1600
	Blowing pressure	MPa	3.5
	Blowing air consumption	L/min	5000**
Chilled water	Pressure	MPa	0.3
	Temperature	°C	10-12
	Flow	L/min	40
Machine	Main body measurement (LxWxH)	m	3.6x2.2x2.2
	Weight	Kg	4000

- \* \*Depends on the container design. \*\* Depends on the container design and operating condition
- \* This machine has 3 heating zones, 10 layers heating lamps.
- \* Specifications are subject to change without advance notice.

AL-3000 Foot Plan

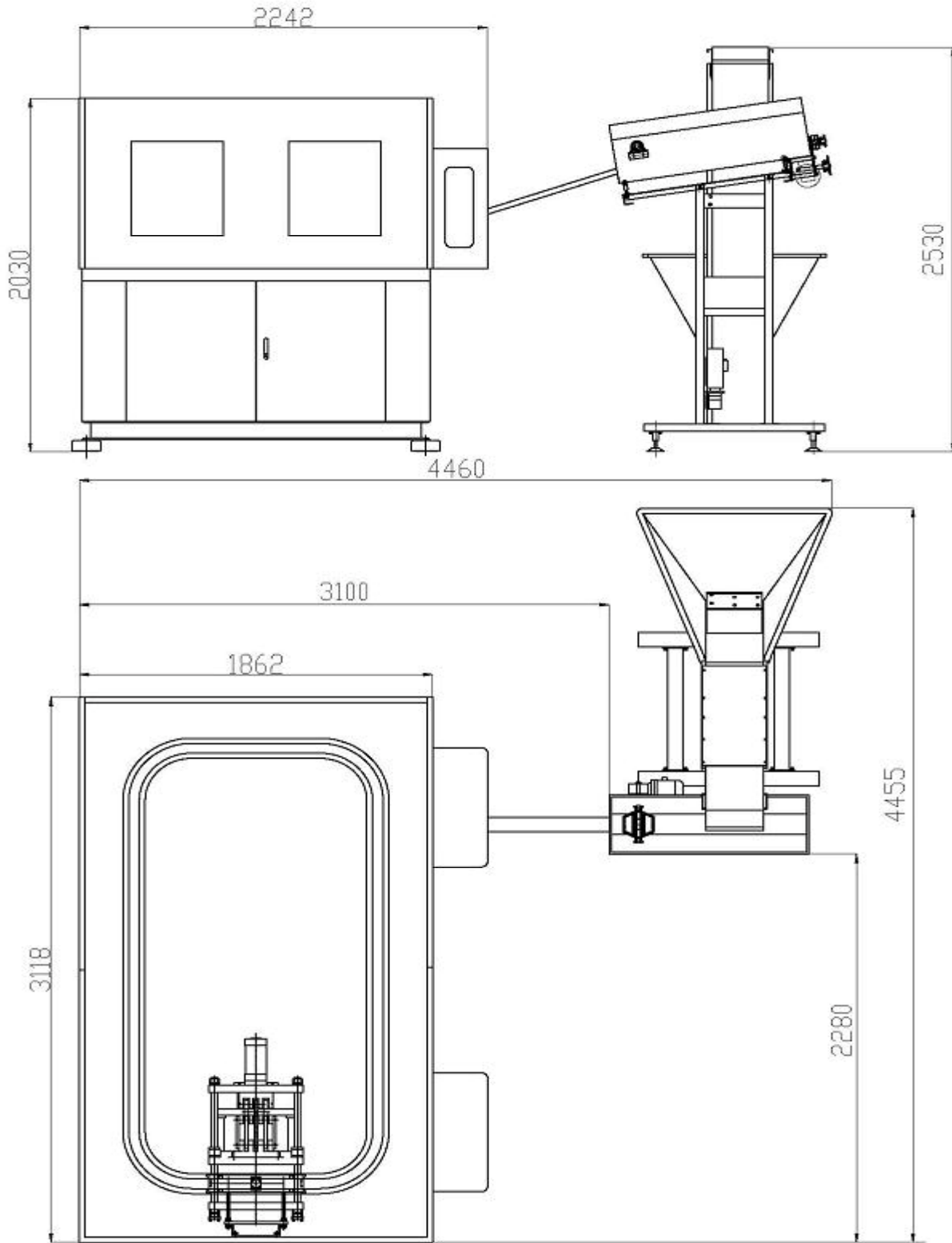

AL-3000 FOOT PLAN