



AL-3000S



Specifications

	Number of cavity		3
	Theoretical capacity	BPH	2700*
Container	Max. container volume	liter	0.6
	Max. outside neck	mm	38
	Max. container diameter	mm	65
	Max. container height	mm	240
Power	Rated power	KW	43
	Max. heating power	KW	40
Compressed air	Operating pressure	MPa	0.7
	Operating air consumption	L/min	1600
	Blowing pressure	MPa	3.5
	Blowing air consumption	L/min	2000**
Chilled water	Pressure	MPa	0.3
	Temperature	°C	10-12
	Flow	L/min	40
Machine	Main body measurement (LxWxH)	m	2.6x2.2x2.2
	Weight	Kg	3500

- * This machine is ideal for making small bottles.
- ** Depends on the container design. ** Depends on the container design and operating condition .
- * This machine has 2.5 heating zones, 8 layers heating lamps.
- * Specifications are subject to change without advance notice.

AL-3000S Foot Plan

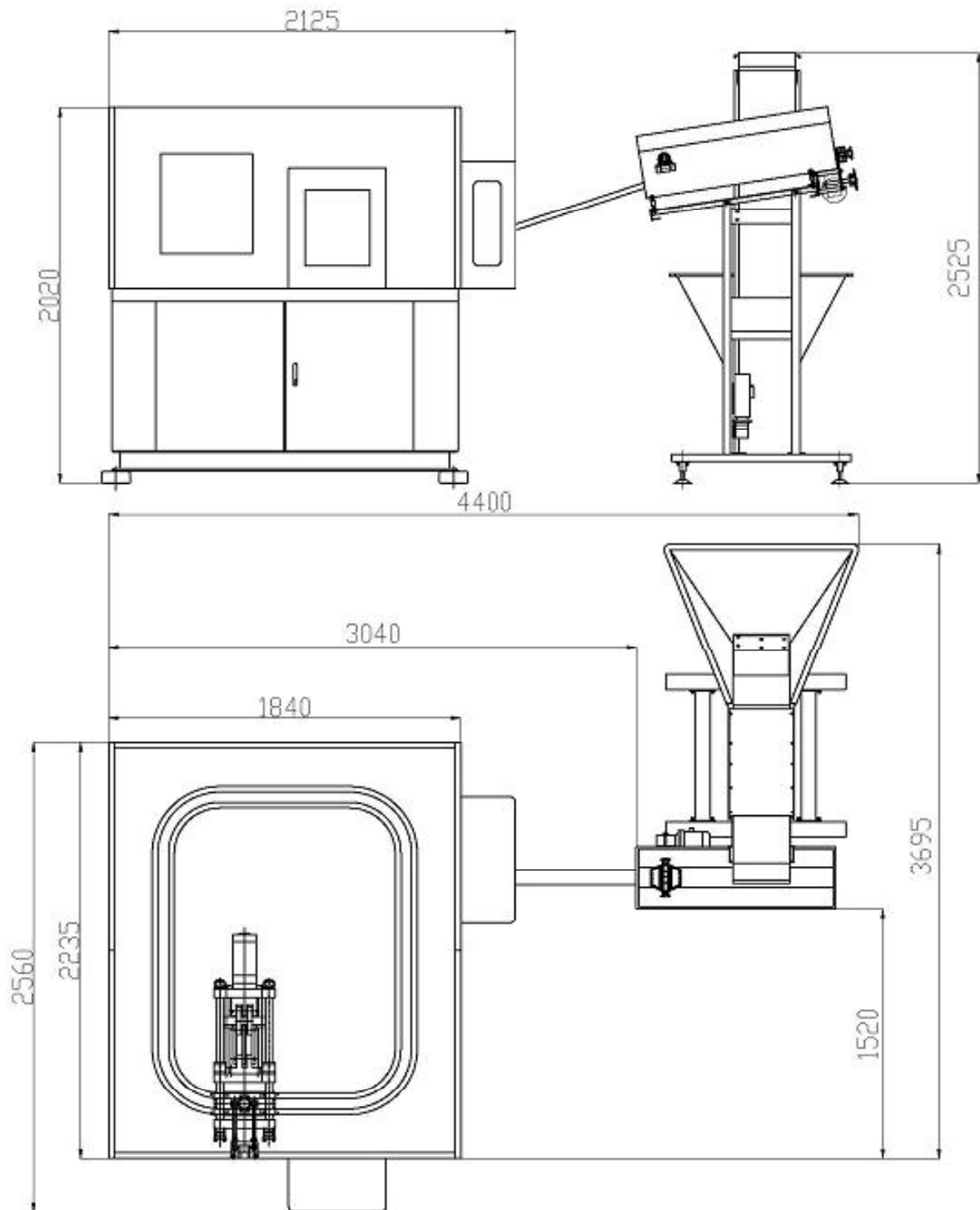

The Stretch Blow Molding Machine Makes Your Own Bottles